

Phylogeography of the longhorn cactus beetle *Moneilema appressum* LeConte (Coleoptera: Cerambycidae): was the differentiation of the Madrean sky islands driven by Pleistocene climate changes?

CHRISTOPHER IRWIN SMITH and BRIAN D. FARRELL

Museum of Comparative Zoology, Harvard University, Cambridge, MA 02138

Abstract

Although it has been suggested that Pleistocene climate changes drove population differentiation and speciation in many groups of organisms, population genetic evidence in support of this scenario has been ambiguous, and it has often been difficult to distinguish putative vicariance from simple isolation by distance. The sky island communities of the American Southwest present an ideal system in which to compare late Pleistocene range fragmentations documented by palaeoenvironmental studies with population genetic data from organisms within these communities. In order to elucidate the impact of Pleistocene climate fluctuations on these environments, biogeographic patterns in the flightless longhorn cactus beetle, *Moneilema appressum* were examined using mitochondrial DNA sequence data. Gene tree relationships between haplotypes were inferred using parsimony, maximum-likelihood, and Bayesian analysis. Nested clade analysis, Mantel tests, and coalescent modelling were employed to examine alternative biogeographic scenarios, and to test the hypothesis that Pleistocene climate changes drove population differentiation in this species. The program MDIV was used to estimate migration and divergence times between populations, and to measure the statistical support for isolation over ongoing migration. These analyses showed significant geographic structure in genetic relationships, and implicated topography as a key determinant of isolation. However, although the coalescent analyses suggested that a history of past habitat fragmentation underlies the observed geographic patterns, the nested clade analysis indicated that the pattern was consistent with isolation by distance. Estimated divergence times indicated that range fragmentation in *M. appressum* is considerably older than the end of the most recent glacial, but coincided with earlier interglacial warming events and with documented range expansions in other, desert-dwelling species of *Moneilema*.

Keywords: coalescent analysis, MDIV, *Moneilema*, nested clade analysis, Pleistocene climate change, sky islands

Received 22 November 2004; revision received 21 February 2005; accepted 13 May 2005

Introduction

Climate changes and glaciation during the Pleistocene have been a subject of intense interest to evolutionary biologists since the 1850s (Darwin 1859; Wallace 1862) and the literature has seen much speculation about the role that glacial/

interglacial cycling may have played in the diversification of many plants and animals (Mayr 1942, 1963; Hewitt 2000; Wilf *et al.* 2003). Although the isolation of temperate species in glacial refugia during ice ages, and the fragmentation of oceanic islands, boreal forests, and montane ecosystems during the interglacials both represent possible mechanisms that might have driven the speciation of terrestrial organisms, evidence in support of these scenarios remains equivocal. Whereas many studies have revealed phylogeographic patterns that are consistent with range fragmentation in

Correspondence: Christopher Irwin Smith, Present address: Department of Biological Sciences, University of Idaho, Moscow, Idaho 83844. Fax: 208-885-7905; E-mail: csmith@uidaho.edu

response to Pleistocene climate changes (Brower 1996; Hewitt 1996; Knowles 2000, 2001; Knowles & Otte 2000; Ayoub & Riechert 2004) it is often difficult to distinguish historical range fragmentation from neutral population genetic processes such as isolation by distance (Wakeley 1996, 2000; Nielsen & Slatkin 2000; Nielsen & Wakeley 2001). Additionally, recent analyses suggests that many modern species pairs diverged long before the Pleistocene (Klicka & Zink 1997, 1999; Stepan *et al.* 2003), suggesting that Pleistocene climate changes have not played a major role in generating species diversity.

The American arid regions offer unusual opportunities to investigate the role of Pleistocene climate changes on the diversification of terrestrial organisms. Tremendous variation in altitude, rainfall, and climate within this region permits the coexistence of a remarkable diversity of organisms and biotic communities within close proximity of one another (Warshall 1994). Additionally, the extreme aridity of these environments has allowed the preservation of a rich record of plant and animal material in ancient rodent nests, that records significant range changes in many species coincident with the end of the last ice age (Van Devender 1990a, b). This record documents the distribution of desert environments from as much as 50 000 years ago and records a dramatic shift in the distribution of many species at the end of the most recent glacial period (Van Devender 1990a, b; Thompson & Anderson 2000).

Although the consequences of late Pleistocene and early Holocene climate changes varied considerably between species (Brown & Lomolino 1998; Van Devender 1990b), the overall effect was a remarkable shift in the dominant habitat type in these regions. Plants that had previously dominated much of the southwestern United States, including pinyon pine (*Pinus edulis*), juniper (*Juniperus* spp.), and the Joshua tree (*Yucca brevifolia*) retreated to higher elevations, in the face of advancing desert environments. Large, contiguous areas of cool climate habitats were fragmented into isolated, mountain-top refugia and replaced in lower elevations by a cactus- and legume-dominated desert scrub (Thompson & Anderson 2000). The formerly dominant, cool-climate plants have persisted into the present in patchy, mountain-top refugia dubbed 'The Sky Islands' (Heald 1951) or 'The Madrean Archipelago' (McCord 1994; Warshall 1994).

The formation of the Madrean Archipelago may have presented opportunities for rapid differentiation, diversification, and perhaps speciation in cool-climate organisms following their isolation in disjunct mountain ranges. This possibility has motivated a great number of biogeographic studies of this region (Linhart & Permoli 1994; McCord 1994; Sullivan 1994; Slentz *et al.* 1999; Barber 1999a, b; Maddison & McMahon 2000; Masta 2000; Boyd 2002). Although these previous studies have revealed significant and remarkable genetic structure in species from these

regions, it has been difficult to draw particular conclusions about the origins of that structure.

The cerambycid beetle *Moneilema appressum* LeConte offers great potential for exploring the consequences of habitat shifts since the last glacial maximum on the population structure of organisms living in southwestern environments. *Moneilema appressum* occurs above *c.* 1300 m throughout southeastern Arizona, central New Mexico, and central Mexico, occurring primarily in patchily distributed, semidesert grasslands and mixed woodlands that are analogous to the communities that formerly dominated much of the southwestern desert regions. *Moneilema appressum* has a very narrow diet breadth, feeding almost exclusively on two sister species of cholla cacti, *Opuntia spinosior* and *Opuntia imbricata* (but see Lingafelter 2003). These plants currently occur across a relatively broad altitudinal range (*c.* 500 to *c.* 2000 m), but the packrat midden data indicate that these plants formerly occupied an even broader distribution, and may have experienced a range fragmentation coincident with global climate changes (McCarten 1981). Likewise, fossil insect remains from packrat middens indicate that, like other desert organisms, ground-dwelling insects experienced dramatic range and distribution changes during the middle Holocene (Elias 1987; Elias & Van Devender 1992; Elias *et al.* 1995). Finally, because *M. appressum* is flightless, dispersal is unlikely to have erased evidence of past range changes, and this expectation is borne out by recent phylogeographic studies indicating that lowland desert species of *Moneilema* retain genetic evidence of population expansions that occurred during the Pleistocene interglacials (Smith & Farrell 2005).

Here, we present a genealogy of mitochondrial DNA sequences drawn from *M. appressum*. These data are used to address several questions about population structure in this species and to examine the potential role of Pleistocene climate changes in the differentiation of sky island ecosystems. First, we examine whether the pattern of genetic diversity in this species shows geographic structure. Second, we consider whether geographic structure is best explained by historical habitat fragmentation or by ongoing restricted gene flow and isolation by distance using Templeton's nested clade analysis (NCA) and estimates of migration rates inferred using the program MDIV. Finally, we consider whether climate changes since the last glacial could have been the causal mechanism underlying population subdivision by using MDIV to infer divergence times between populations and between regions.

Materials and methods

Insect collections and selection of study sites

Moneilema appressum was collected from 16 locations in New Mexico, Arizona, Chihuahua and Durango (see Fig. 1,

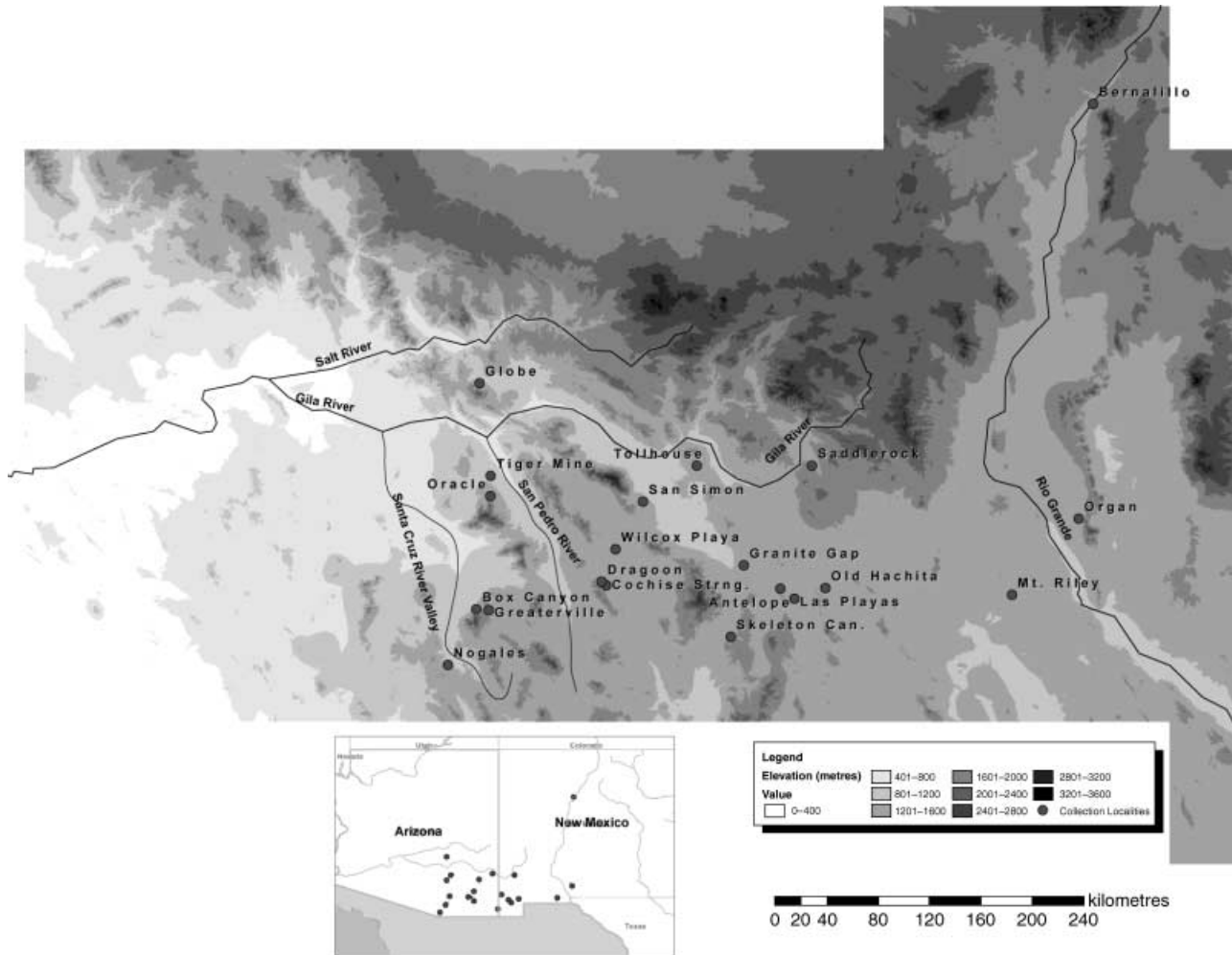

Fig. 1 Map of the study area, showing major rivers and topographic data from Digital Elevation Models (DEM). Dots indicate collection localities for *Moneilema appressum*. Location of study area shown in inset.

Table 1). Collection localities were chosen by consulting previous collection data in published accounts (Raske 1966; Linsley & Chemsak 1984) and by examining museum specimens at the Museum of Comparative Zoology at Harvard, the University of Arizona insect collection, the Essig Museum at UC Berkeley, the California Academy of Sciences, and the Instituto de Biología at the Universidad Autónoma de México (UNAM). Biotic community maps (Brown 1994) were consulted to identify potential new populations that might be informative in reconstructing Pleistocene climate changes. The latitude and longitude coordinates of each locality were recorded using a handheld Garmin GPS 12, or E-map GPS unit (see Table 1).

Genetic analysis

Specimens were selected for sequencing to obtain representative samples from across the species' range and to capture an accurate picture of the genetic diversity within

populations. Because the position of *Moneilema* within the Lamiinae is not known, several outgroup taxa were selected for sequencing, including specimens of *Moneilema gigas* LeConte, *Moneilema armatum* LeConte, and the lamiine cerambycid beetles, *Liopinus* spp. Linsley and Chemsak, *Essostrutha* spp. Thomson, and *Tetraopes annulatus* LeConte.

Whole genomic DNA was isolated from these individuals using the salting out procedure described in Sunnucks & Hales (1996). Genetic material was resuspended in 50 μ L of 1 \times buffer TE, and stored at -20°C pending polymerase chain reaction (PCR) amplification.

PCRs were performed using a modification of the procedure described in Palumbi (1996), using 2 μ L of undiluted whole genomic template and 2 μ L of a 25 mM MgCl_2 catalyst in a 50- μ L reaction. Reagent concentrations were as follows: 8 mM dNTPs, 10 μ M oligonucleotide primers, 10 \times *Taq* buffer. Reactions used a 52 $^{\circ}\text{C}$ annealing temperature, held for 90 s, and a 60 $^{\circ}\text{C}$ extension temperature, held for 2 min. This procedure was used to amplify 1422 bp including

Table 1 Location of sampled populations

Locality name	Coordinates	Location	No. of individuals	GenBank Accession nos
Antelope, NM	31°55.560'N 108°43.050'W	Pyramid Mts, New Mexico off NM Hwy 9 between Rodeo and Hachita, NM Hidalgo Cty, NM	3	AY650991–AY650993
Bernalillo	35°18.949'N 106°31.820'W	Interstate 40 Exit 242 North of Albuquerque, Bernalillo Cty, NM	2	AY650994 AY650995
Box Canyon	31°46.973'N 110°50.300'W	Sta Rita Mts, Box Canyon Road between Greaterville, AZ and Sta. Rita Experimental Range HQ, Santa Cruz Cty, AZ	3	AY650968–AY650970
Cochise Stronghold	31°56.927'N 109°55.980'W	Dragoon Mts, Ironwood Road, East of Cochise Ranger Station, Cochise Cty, AZ	9	AY650973–AY650977; AY650981–AY650984
Dragoon	31°58.610'N 109°57.840'W	Dragoon Mts, Forest Service Road 795, North of Intersection w/Ironwood Road, Cochise Cty, AZ	1	AY650972
Globe	33°21.606'N 110°48.930'W	Pinal Mts, Forest Service Road 55 South of Claypool, Gila Cty, AZ	1	AY650985
Granite Gap	32°5.318'N 108°58.390'W	Peloncillo Mts, NM Hwy 80 North of Rodeo, Hidalgo Cty, NM	4	AY650955; AY651003–AY651005
Greaterville, AZ	31°46.515'N 110°45.100'W	Sta Rita Mts, Greaterville Road, West of AZ Hwy 83	2	AY650953 AY650956
Hidalgo de Parral, CHI	26°52.183'N 105°36.259'W	Mexico Hwy 24, South of Hidalgo de Parral, Chihuahua, Mexico	1	AY650999
Las Playas Valley	31°51.357'N 108°37.150'W	Las Playas Valley Road, South of Intersection w/NM Hwt 9, Hidalgo Cty, NM	4	AY650954
Mt Riley	31°52.925'N 107°5.750'W	East Portillo Mts, Cty Road A005 north of County Road A003 near US/Mexico Border, Doña Ana Cty, NM	4	AY650957 AY650996 AY650997 AY651008
Nogales, AZ	31°23.575'N 110°48.954'W	Pajarito Mts, Forest Service Road 222 Near Arizona Hwy 289, east of Interstate 19, Sta Cruz Cty, AZ	4	AY650961–AY650964
Old Hachita Road	31°55.831'N 108°24.210'W	Little Hatchet Mts, Old Hachita Road Near Intersection with New Mexico Hwy 9, Grant Cty, NM	3	AY650950 AY650951 AY651006
Oracle, Arizona	32°34.363'N 110°44.354'W	Sta Catalina Mts, Arizona Trail Off Mt Lemon Hwy Road, Pinal Cty, AZ	2	AY650960 AY650965
Organ, NM	32°24.854'N 106°37.880'W	US 70 Between Las Cruces and White Sands Missile Range, Doña Ana Cty, NM	5	AY650986–AY650990
Saddlerock Canyon	32°47.070'N 108°29.800'W	Big Burro Mts, Saddlerock Canyon Road off US 180 west of Silver City, Grant Cty, NM	1	AY650952
San Simon	32°31.970'N 109°40.520'W	Pinaleño Mts, Hwy 191 South of Safford, Graham Cty, NM	1	AY650980
Skeleton Canyon	31°35.425'N 109°3.795'W	Peloncillo Mts, Skeleton Canyon Road of AZ Rte 80. Southwest of Rodeo, NM	3	AY650947 AY650949 AY651002
Tiger Mine	32°38.294'N 110°44.354'W	Catalina Mts, off Arizona 83, Northeast of Oracle, AZ	2	AY650958 AY650959
Tollhouse Canyon	33°46.423'N 109°18.680'W	Peloncillo Mts, Hwy 191 west of Clifton, Greenlee Cty, AZ	2	AY650966 AY650967
Wilcox Playa	32°12.088'N 109°52.040'W	Railroad Avenue, Southwest of Wilcox, Cochise Cty, AZ	6	AY650945 AY650946 AY650948 AY650971 AY651000 AY651001
La Zarca, DGO	25°48.361'N 104°46.675'W	Mexico Hwy 24, South of La Zarca, Near Chihuahua/Durango Border, Durango, Mexico	1	AY650998

portions of the cytochrome oxidase I (COI) gene. For most individuals, two separate fragments were amplified: 1049 bp from position 1541–2590, and 780 bp from position 2183 to 2963, with a 399-bp region of overlap. Primers used for PCR amplification included the s1541, a2590, s2183, and a2963 primers described by Farrell (2001).

PCRs were purified using QIAGEN PCR purification kits (QIAGEN, Inc.). DNA sequence data were obtained from these amplified sequences by thermal cycle sequencing using ABI Corporation Dye Terminators or BigDye Terminator reaction mixtures, followed by electrophoresis in 1.0% acrylamide sequencing gels run on an ABI 370 or 377 automated DNA sequencer, or in polymer-filled capillaries in an ABI 3100 capillary sequencer. Multiple sequencing reads using both the sense and antisense primers were obtained for all specimens. Sequence data were analysed using the ABI SEQUENCING ANALYSIS SOFTWARE version 3.4.1 (Applied Biosystems Inc.) and visualized using the SEQUENCHER software package version 3.0 (Gene Codes Corp.). Sequences were easily aligned by eye using MACCLADE version 4.04 (Maddison & Maddison 2001).

Phylogenetic analysis

Phylogeographic patterns were examined by inferring phylogenetic relationships from mitochondrial sequence data, and by comparing these relationships with the species' distribution. All data were analysed in PAUP version 4.0b10 (Swofford 2002) using parsimony-based searches with all characters equally weighted. Shortest trees were found by heuristic searches with 100 random addition sequences starting from random trees. After an initial search, the heuristic search was repeated with 100 000 addition sequences starting from random trees and keeping only trees as short or shorter than those found in the first search. By this method it was possible to efficiently search large sections of tree space, concentrating on those regions that might contain global optima. Support for the relationships found in these searches was evaluated by a 100 replicate bootstrap analyses with 10 addition sequences per replicate.

Maximum-likelihood models were selected using MODELTEST version 3.06 (Posada & Crandall 1998), and likelihood-based searches were completed in PAUP version 4.0b10 (Swofford 2002). These searches employed a heuristic search strategy using 30 addition sequences starting from random trees.

Bayesian analyses were completed in MRBAYES version 3.01 (Huelsenbeck & Ronquist 2001) using two runs of 5 million generations each. Each run used four separate Markov chains, with heating equal to 0.1, sampling every 100 generations. Results of each run were compared in MRBAYES to evaluate the consistency of clade posterior probabilities across runs. A 100 000-generation burn-in was selected based on the point at which all parameters appeared

to have reached stationarity. Forty-nine thousand post-burn-in trees from each run were pooled and imported into PAUP. Majority rule consensus trees were calculated from the pooled post-burn-in trees to determine clade posterior probabilities.

Nested clade analysis

In order to implement the NCA, a gene network was computed using TCS version 1.18 (Clement *et al.* 2000). The program was set to estimate the 95% reconnection limit between haplotypes. In order to explore the data set thoroughly, the reconnection limit was increased manually to determine the number of mutational steps between the most divergent haplotypes, but in order to be statistically conservative, haplotypes that could not be connected to the main network at the 95% reconnection limit were excluded. Likewise, because of the considerable geographic distance between the Mexican samples and the rest of the individuals in this study, and because of inadequate sampling in the regions between these areas, the two haplotypes from central Mexico were excluded from these analyses. The resulting gene network was then grouped into 1-, 2-, 3-, 4-, 5- and 6-step clades by hand, according to the methods described by Templeton *et al.* (1987), and employing special modifications of these rules described by Templeton & Sing (1993), to handle equivocal groupings of haplotypes. To measure the association of geography with the hierarchical structure in the gene network, the data were analysed using GEODIS version 2.0 (Posada *et al.* 2000). Geographic distances between collection localities were calculated by GEODIS from GPS coordinates. Output from GEODIS was interpreted using the inference key developed by Templeton (1998) and the special modifications of that key described in Templeton (2004).

Coalescent modelling

Distinguishing between alternative biogeographic hypotheses has been extremely difficult in the past, and biogeographic studies have often been unable to rule out static processes such as isolation by distance. Recently, however, several generalized likelihood models have been developed to distinguish historical isolation from ongoing migration (Wakeley 1996; Nielsen & Slatkin 2000; Nielsen & Wakeley 2001). These approaches have been integrated in a general coalescent model using a Markov chain Monte Carlo (MCMC) method to search parameter space while jointly estimating symmetric migration rates between populations, time to common ancestry, and ancestral population sizes (Nielsen & Wakeley 2001). Here, we examine whether the geographic structure in *M. appressum* is better explained by historical isolation or by ongoing, restricted gene flow, using the model described by Nielsen & Wakeley (2001).

Aligned sequences were compared using the *MDIV* software package (Nielsen & Wakeley 2001). Populations for which there were a sufficient number of samples were compared two at a time, and the parameters Θ , M and T (defined below) were estimated using a 5 000 000-generation MCMC with an additional 500 000-generation burn-in. These contrasts used a finite sites model, and a priori maxima were set for M and T , with $M_{\max} = 6$, and $T_{\max} = 10$. These a priori maxima are based on the assumption that these flightless insects must have inherently low migration rates, and that the oldest divergences within this species could not be more than 12 million years (Myr), the maximum age of the mountains they inhabit. In order to ascertain whether the Markov chains had reached stationarity, multiple runs using starting seeds generated by the system clock were completed for each comparison, and parameter estimates between runs were compared using a Pearson correlation.

To mitigate potential problems due to small sample size, populations were grouped by region (defined a priori based on biogeographic barriers identified in previous studies), and these same parameters were again estimated comparing two regions at a time. We then used the parameter estimates and the probability distributions (properly termed 'credibilities' (Nielsen & Wakeley 2001)) output by the program to test alternative demographic hypotheses by the method described below.

Estimates of migration

We estimated the parameter M ($= Nm$ or the average number of migrants between populations per generation) between pairs of populations and between paired regions. Because an average of one migrant per generation is sufficient to prevent divergence between populations (Wright 1978), we calculated the probability that $M \geq 1$ for contrasts between regions by summing under the credibility curve output by *MDIV*. This calculation was made for contrasts between regions only because small sample sizes in some populations produced very wide confidence intervals in the contrasts between populations. Finally, because the a priori maxima selected can potentially influence the posterior distribution of parameter estimates, the interregional contrasts were repeated twice using alternative values for M_{\max} of 3 and 9, respectively.

In order to investigate the factors that may determine levels of gene flow and genetic isolation, the maximum-likelihood point estimates of M were compared with the geographic distances and topographic barriers to dispersal between populations. Great circle distances between collection localities were calculated using the program *EARTHDISTANCES* (Byers 1999). Topographic barriers to dispersal were determined by referring to topographic maps and GIS data to determine the lowest elevation along a straight-line route between two populations. Matrices of

geographic distances and topographic barriers to dispersal were compared to estimates of M using a Mantel test (Mantel 1967). (These matrices are available from the author for correspondence upon request.) Multiple regressions were performed using the partial Mantel method (Smouse *et al.* 1986). R^2 and P values were calculated for distance and topography alone; then, residuals from each of the two-way comparisons were compared to the third variable using a simple Mantel test. All Mantel and partial Mantel tests were completed using the *FSTAT* software package version 2.9.3.2 (Goudet 2002) with 20 000 permutations each.

Estimates of divergence times

The timing of divergences between populations provides an important test of biogeographic hypotheses, in that the time to common ancestry of two populations must be consistent with the putative historical events that are hypothesized to have driven their divergence. In order to evaluate whether putative range fragmentation in *M. appressum* could have been driven by Pleistocene climate changes, divergence times were calculated from estimates of the parameter T generated by *MDIV* (above). Coalescent time units were converted to years as follows:

$$T_{\text{div}} = T\Theta / (2\mu)$$

where μ is equal to the expected number of mutations that will occur in a sample of n base pairs per generation. In this case we assumed one generation per year (Linsley & Chemsak 1984), and used the maximum-likelihood estimate of Θ ($= 2N_e\mu$) calculated from *MDIV*. The neutral mutation rate was assumed to be 1.5% per Myr, based on a calibration for the closely related *Tetraopes* milkweed beetles (Farrell 2001).

We view this method of inferring divergence times as preferable to traditional molecular clocks for two reasons. First, a conventional molecular clock calculates the time to the most recent common ancestor in a sample of haplotypes, not the divergence time between populations. By definition, the time to common ancestry (TMRCA) must always be greater than the time to divergence between populations (T_{div}). Although this might introduce a negligible amount of error if the time to coalescence in the ancestral population were very small relative to the overall divergence time (for example, between deeply diverged species), it can severely prejudice estimates between recently diverged populations (Arbogast *et al.* 2002). Additionally, although *MDIV* assumes a constant neutral mutation rate, the Poisson model of mutation implemented in coalescent analyses accounts for variance in the time between mutations, which might produce the appearance of non-clocklike behaviour in population-level studies where divergence times may be small relative to the neutral mutation rate.

Results

Collections

A total of 64 individuals were collected (see Table 1). At most locations between one and five individuals were collected and sequenced. Although small sample sizes ultimately limit the strength of the genetic data, high variance in local population density imposes a practical upper limit to sample size. Most sampled populations were from the 'Cochise Filter' region on either side of the continental divide, where the upper Sonoran and Chihuahuan deserts meet between the northern reaches of the Sierra Madre and the southern edge of the Rocky Mountains. Additionally, we sampled four populations from the Santa Cruz River valley near Tucson, Arizona, and two populations from New Mexico east of the Rio Grande River. Although there were very limited data available on the distribution of *Moneilema appressum* from Mexico, we were able to collect from two populations in Central Mexico. One of these was from the Durango/Chihuahua Border, just south of the Hamlet of La Zarca, and the other was just south of the town of Hidalgo de Parral, Chihuahua, in the foothills of the Sierra Madre. Some areas for which *M. appressum* has been recorded were surveyed for this study, but no insects could be collected. These areas include eastern New Mexico, western Texas, and Arizona north of the Mogollon rim; most likely the failure to collect insects in these regions is the result of low population density, which is characteristic of this species across its range, rather than local extinction.

Genetic data

DNA sequence data was deposited in GenBank, under Accession nos AY650945–AY651017. There were 63 unique haplotypes in the 64 individuals sequenced. Of the 1413 bases sequenced, 1010 were invariant. Of the variable sites, 68% were synonymous substitutions. Most of the non-synonymous substitutions were clustered within highly variable regions of the gene, corresponding to regions of the cytochrome oxidase I protein that do not cross the mitochondrial membrane (Saraste 1990), suggesting that most of the genetic variation is either neutral or nearly neutral, and not visible to selection. The data suggest an empirical transitions/transversion ratio of 1.8, and an A–T bias, with empirical base frequencies of A: 0.29661; C: 0.15580; G: 0.15803; T: 0.38955.

Phylogenetic analysis

Parsimony, maximum-likelihood, and Bayesian analyses all identified similar optimal topologies. Parsimony-based searches found 106 equally parsimonious trees, 1877 steps

long. These trees had a consistency index (CI) = 0.4774, a homoplasy index (HI) = 0.5226 and a retention index (RI) = 0.7172. Maximum likelihood-based searches performed in PAUP, using the GTR + I + G model selected by MODELTEST, found a similar topology to that selected under parsimony, which had a log-likelihood score of –11683.64.

The Bayesian analysis converged on a set of trees with a mean likelihood score of $-12\,387.7 \pm 9.74$ after 100 000 generations. A comparison of 1000 randomly selected, post-burn-in trees from each of the two independent Markov chains found that clade posterior probabilities were 99% correlated between runs ($R^2 = 0.998$).

Within *M. appressum* the strict consensus (Fig. 2) identified six clades, corresponding roughly to the geographic relationships between collection localities. Bootstrap analyses found strong support (75–99%), for the monophyly of most of these clades, as well as for the monophyly of the ingroup (100%), although some of the bootstrap scores were less than 60%. Not surprisingly, the posterior probabilities inferred from the Bayesian analysis were consistently higher, between 78% and 100%.

Nested clade analysis

tcs estimated a 95% reconnection limit of 16 mutational steps, leaving 18 haplotypes unincorporated. The unincorporated haplotypes included three from the Santa Cruz River valley, one from Globe, eight from the Continental Divide region, and six from east of the Rio Grande. By manually increasing the reconnection limit it was possible to connect all of these except the one haplotype from globe with a reconnection limit of 25 steps. The haplotype from Globe was separated the main network by 29 mutational steps. However, as described above, because including these haplotypes would require connections that exceeded the 95% – and even the 90% – reconnection limits, they were excluded from this analysis.

The gene network produced by tcs using the 95% reconnection limit of 16 mutational steps is shown in Fig. 3a, and the nested clades are shown in Fig. 3b and 3c. The nested clades were similar, but not identical to the groupings identified in the phylogenetic analysis; nested clade 6-1 represents haplotypes from the Sulfur Springs Valley (clade B in the phylogenetic analysis), and clade 6-3 contains haplotypes from the continental divide region (clade D in the phylogenetic analysis), but the internal clade 6-1 includes haplotypes from several different regions, including the Santa Cruz River valley (clade A in the phylogenetic analysis), the Continental Divide (clades C and D in the phylogenetic analysis), and a single haplotype from east of the Rio Grande (clade E in the phylogenetic analysis).

Analysis of clade distances using GEODIS found significant values only in one 5-step clade, one 6-step clade, and in the total cladogram (see Table 2). These results were



Fig. 2 Strict consensus of parsimony, maximum-likelihood, and Bayes consensus trees. Text indicates the geographic distribution of clades. Nodal support is given below branches as follows: Bayesian posterior probabilities/parsimony bootstraps.

Table 2 Results of nested clade analysis of *M. appressum* (6-step clades only)

Clade	Distribution	Chi-squared statistic	P	Biogeographic interpretation
5-2	Widespread – All major regions	65.70	0.001	Inadequate sampling to distinguish isolation by distance from fragmentation
6-1	Sulfur Springs Valley	2.14	0.55	No significant structure
6-2	Widespread – All major regions	24.00	0.009	Isolation by distance
6-3	Continental Divide	7.00	0.37	No significant structure
Total Cladogram	~	52.97	< 0.0001	Isolation by distance

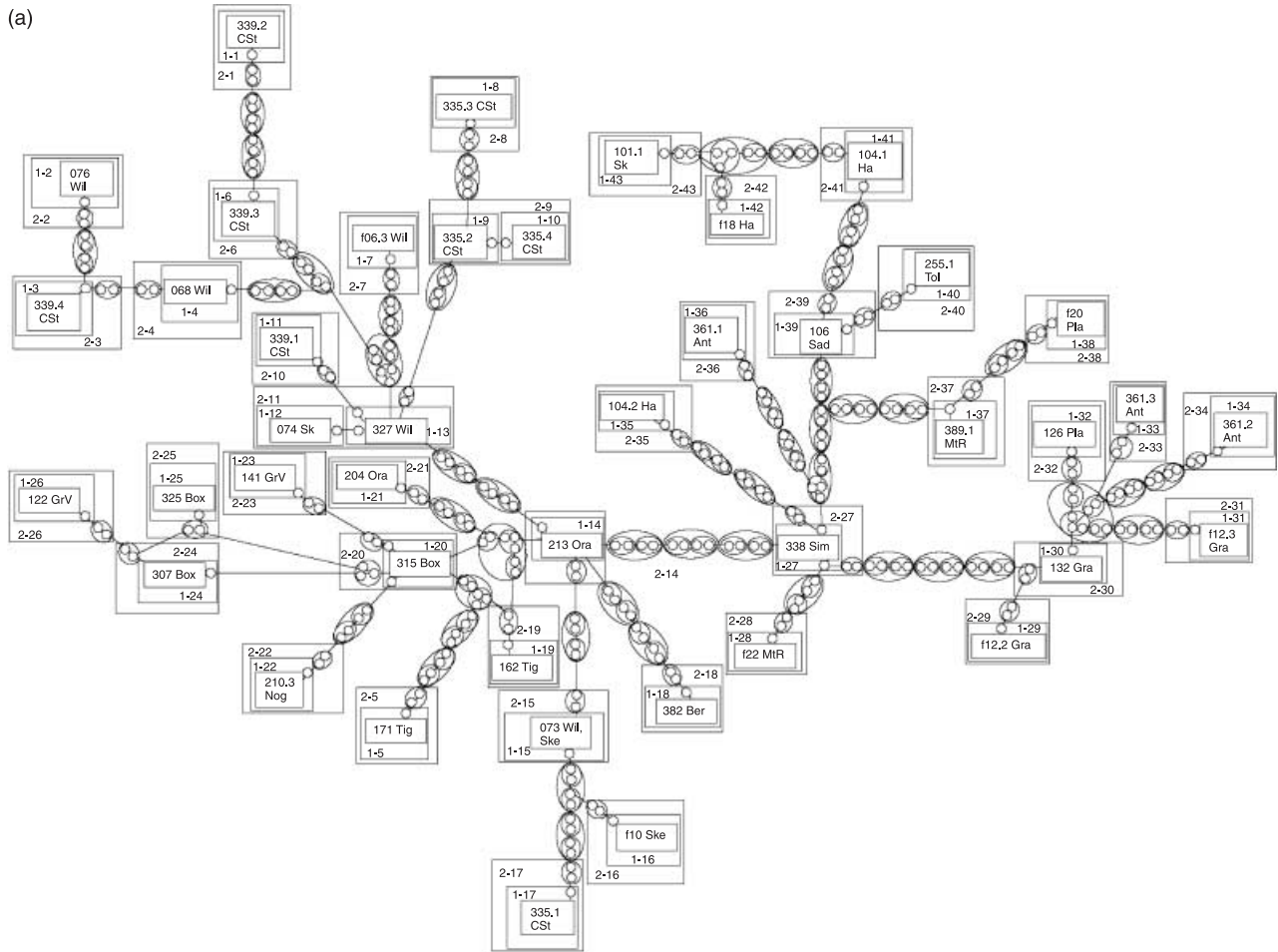

Fig. 3 (a) Gene network inferred from rcs showing zero-, one- and two-step clades from the nested cladogram. Haplotype distributions are abbreviated as follows: Antelope, Ant; Bernalillo, Ber; Box Canyon, Box; Cochise Stronghold, CSt; Dagoon, Dra; Globe, Glo; Granite Gap, Gra; Greaterville, GrV; Las Playas, Pla; Mount Riley, MtR; Nogales, Nog; Old Hachita, Ha; Oracle, Ora; Organ, Org; Saddlerock Canyon, Sad; San Simon, Sim; Skeleton Canyon, Ske; Tiger Mine, Tig; Tollhouse, Tol; Wilcox, Wil. (b) Gene network inferred from rcs showing two-, three- and four-step clades from the nested cladogram. Clade distributions are abbreviated as above. (c) Gene network inferred from rcs showing four-, five- and six-step clades from the nested cladogram. Clade distributions are abbreviated as above.

interpreted as follows: clade 5-2 showed a pattern consistent either with isolation by distance or allopatric fragmentation (the existence of unsampled potential habitat between the Santa Catalina and Santa Rita Mountains within the Santa Cruz River valley makes it impossible to distinguish between these alternatives), clade 6-2 showed a pattern consistent with isolation by distance, and the total cladogram showed a pattern consistent with isolation by distance. In each of these cases, chi-squared tests indicate strong statistical support for the significance of the observed geographic structure ($P < 0.01$).

Coalescent estimates

Parameter estimates from separate runs were highly correlated; estimates of M , Θ , and T were 99%, 95% and

90% correlated between independent runs, respectively. Estimates of M between populations and between regions are shown in Tables 3 and 4. Migration rates between populations varied from 0.012 between Organ and Tollhouse Canyon to 2.84 between the adjacent populations of Wilcox and Cochise Stronghold. However, for a very few contrasts where there were a small number of sequences per populations, there was no single maximum-likelihood estimate of migration. These contrast were excluded from subsequent analysis, and are indicated by ^{****} in Table 3.

A comparison of migration estimates with topography (Fig. 4) suggests that populations separated by valleys lower than 1200 m are effectively isolated. Likewise, there was a marked effect of distance on migration rates and there appears to be substantial attenuation of gene flow between populations separated by more than 200 km

(b)

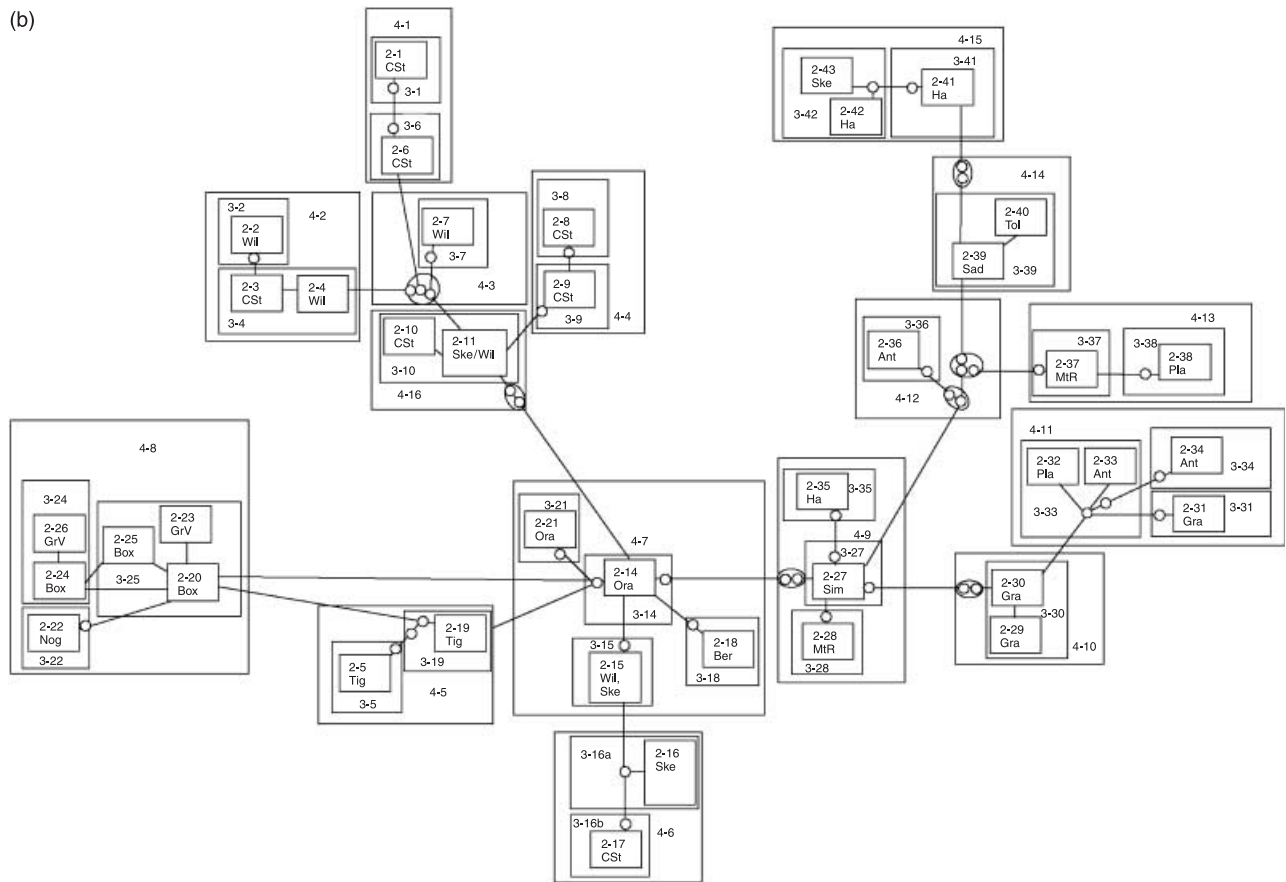

(c)

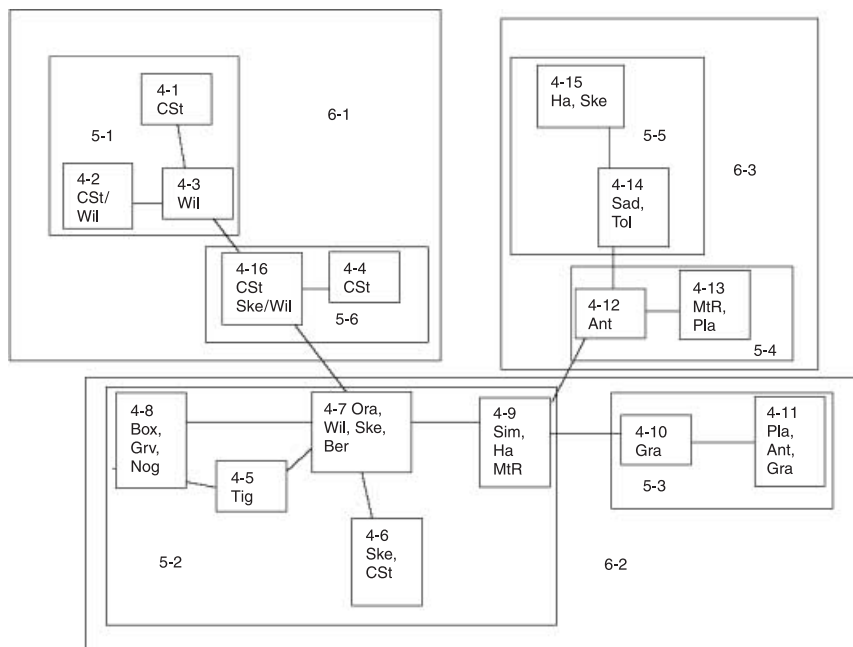

Fig. 3 Continued

Table 3 Maximum-likelihood point estimates of symmetric, per-generation migration rates between pairs of populations (upper triangle); and maximum-likelihood point estimates of divergence times between populations (lower triangle). ***;indicates contrasts in which there were multiple maximum-likelihood optima

	Santa Cruz River Valley			Sulfur Springs			Continental Divide			East of Rio Grande				
	Oracle	Greaterville	Nogales	Cochise Stronghold	Wilcox	Skeleton Canyon	Granite Gap	Tollhouse Canyon	Antelope	Old Hachita	Las Playas	Mount Riley	Organ	Bernalillo
Oracle	/	0.396	0.516	0.084	0.084	0.696	0.072	0.144	0.048	0.276	0.096	0.120	0.084	0.312
Greaterville	224 000	/	0.324	0.096	0.108	0.096	0.072	0.264*	0.072	0.084	0.060	0.144	0.048	0.036
Nogales	436 000	444 000	/	0.096	0.072	0.192	0.096	0.120	0.108	0.132	0.086	0.120	0.048	0.120
Cochise Stronghold	1 124 000	1 137 000	1 372 000	/	2.84	1.404	0.252	0.396	0.264	0.264	0.264	0.360	0.096	0.168
Wilcox	730 000	841 000	1 361 000	129 000	/	1.080	0.020	0.156	0.072	0.120	0.120	0.072	0.036	0.108
Skeleton Canyon	624 000	970 000	1 467 000	498 000	654 000	/	0.560	***	0.408	1.704	0.444	0.708	0.108	0.216
Granite Gap	1 661 000	966 000	1 207 000	1 035 000	1 053 000	415 000	/	0.516	1.992	0.516	0.864	1.188	0.024	0.180
Tollhouse Canyon	823 000	458 000	1 265 000	1 098 000	1 014 000	786 000	581 293	/	***	1.14	***	***	0.012	0.276
Antelope	1 387 000	1 120 000	1 460 000	910 000	975 000	454 000	213 000	783 000	/	0.624	***	***	0.060	0.168
Old Hachita	881 000	1 352 000	1 337 000	986 000	917 000	272 000	451 000	560 000	295 000	/	1.260	1.644	0.060	0.156
Las Playas	1 436 000	1 094 000	1 496 000	1 020 000	937 000	599 000	495 000	511 000	391 000	387 000	/	2.62	0.072	0.156
Mount Riley	1 426 000	1 049 000	1 584 000	1 016 000	985 000	600 000	417 000	399 000	532 000	487 000	333 000	/	0.108	0.156
Organ	1 294 000	1 196 000	1 048 000	1 365 000	1 147 000	1 281 000	1 306 000	1 037 000	846 000	990 000	882 000	1 142 000	/	0.264
Bernalillo	965 000	1 139 000	1 048 000	1 608 000	1 306 000	1 381 000	1 215 000	1 589 000	1 389 000	1 267 000	1 108 000	1 473 000	439 000	/

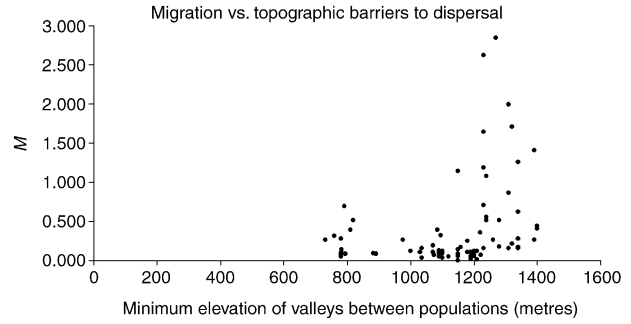

Fig. 4 Maximum-likelihood point estimates of symmetric, per-generation migration rates between pairs of populations inferred by MDIV, plotted against the lowest elevation along a straight-line route between those populations.

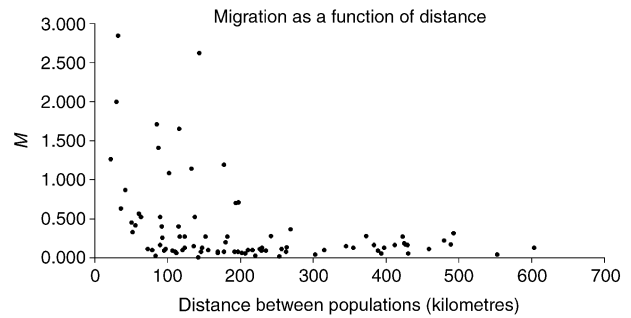

Fig. 5 Maximum-likelihood point estimates of symmetric, per-generation migration rates between pairs of populations inferred by MDIV plotted against the great circle distance between those populations.

(see Fig. 5). Partial Mantel tests suggest that the associations of migration rates with topography and distance are both significant ($P = 0.0185$ and 0.003 , respectively), but that there was a significant residual effect of topography on migration rates even after removing the effect of geographic distance ($P = 0.009$).

Estimates of migration rates between regions were generally low (see Table 4) and were significantly less than one in three of the six contrasts ($P < 0.05$). Additionally, the estimates of M between the Santa Cruz River valley and the Continental Divide region and between the Continental Divide and the area east of the Rio Grande were both quite low, although only marginally significant. However, between the adjacent Sulfur Springs valley and the Continental Divide region the estimated number of migrants per generation was close to one, suggesting that there is indeed appreciable gene flow occurring between these contiguous regions. This inference is also borne out by phylogeographic patterns (see below).

Rerunning the interregional analyses using alternative values for M_{max} indicated that the a priori maxima had a slight influence on both the maximum likelihood estimates and the posterior distribution of M , but neither effect is

Table 4 Estimates of symmetric, per-generation migration rates between regions (lower triangle), and the probability that migration rates are greater than or equal to one (upper triangle), estimated using alternative values for M_{\max} , the a priori maximum migration rate between regions

	Sta Cruz River Valley	Sulfur Springs	Continental Divide	East of Rio Grande
$M_{\max} = 3$				
Sta Cruz River	—	$P = 0.03$	$P = 0.13$	$P = 0.04$
Sulfur Springs	0.02	—	$P = 0.57$	$P = 0.03$
Continental Divide	0.29	0.93	—	$P = 0.06$
East of Rio Grande	0.04	0.10	0.11	—
$M_{\max} = 6$				
Sta Cruz River	—	$P = 0.04$	$P = 0.15$	$P = 0.05$
Sulfur Springs	0.12	—	$P = 0.65$	$P = 0.03$
Continental Divide	0.26	0.96	—	$P = 0.12$
East of Rio Grande	0.06	0.08	0.18	—
$M_{\max} = 9$				
Sta Cruz River	—	$P = 0.03$	$P = 0.12$	$P = 0.06$
Sulfur Springs	0.04	—	$P = 0.67$	$P = 0.05$
Continental Divide	0.31	1.08	—	$P = 0.15$
East of Rio Grande	0.04	0.09	0.13	—

significant (t -test for dependent samples, $P = 0.072$, and 0.244, respectively).

Estimates of divergence times

Estimates of divergence times produced by the coalescent model are shown in Table 3. The maximum-likelihood estimates of divergence time varied from *c.* 129 000 years between Wilcox and Cochise Stronghold, to *c.* 1.6 Myr for the divergence time between Cochise Stronghold and Bernalillo, NM. Within regions, the majority of divergence time estimates were between 300 000 and 500 000 years, but between regions, most estimates were between 1 and 1.5 Myr.

Discussion

A comparison of the phylogenetic relationships within this species with the regional geography suggests a high degree of geographic structure (see Figs 2 and 6), as each of the major clades identified corresponds to a group of geographically clustered populations. There is strong support for the monophyly of populations sampled from the Santa Cruz River valley, including the Santa Catalina, Santa Rita, and Pajarito Mountains (clade 'A'). These populations are separated from the rest of the species' range by the San Pedro River, and were found to be monophyletic under each of the optimality criteria, with strong bootstrap support (99%) and high Bayesian posterior probability (100%). Similarly, populations from the eastern side of the Rio Grande, including individuals from Organ, and Bernalillo, New Mexico were strongly supported as

monophyletic (Clade E) in the bootstrap (85%) and Bayesian analyses (100%).

Additionally, all three optimality criteria identified the populations from Central Mexico as a basal clade within the ingroup, with 100% bootstrap support and 100% Bayesian posterior probability. There was relatively high sequence divergence between these populations and the rest of the ingroup (> 11% on average). These data, together with their disjunct distribution and a combination of morphological features that is unique within the genus (C. Smith, unpublished) suggest that these populations may represent a distinct, undescribed species, sister to *Moneilema appressum sensu stricto*.

However, there was also evidence in phylogeographic relationships for appreciable levels of gene flow between some regions. Individuals sampled from the populations in the Sulfur Springs river valley (Wilcox Playa, Cochise Stronghold, and Dragoon) belonged to three separate mitochondrial lineages (clades B, C and D), each of which was well supported in the Bayesian analysis (78–100% posterior probability). Clade 'C', for example, contained individuals from Wilcox and Skeleton Canyon. It is possible that clade 'C' represents a poorly sampled mitochondrial lineage that would encompass populations from across the Sulfur Springs and San Simon valleys, but the inclusion of sequences from two rather distant populations in this clade suggests appreciable levels of gene flow within this region. Likewise, clade 'D' contained both individuals from the continental divide region, and one sequence from Cochise Stronghold in the Sulfur Springs Valley. There was also indication of significant gene flow between populations within the continental divide region.

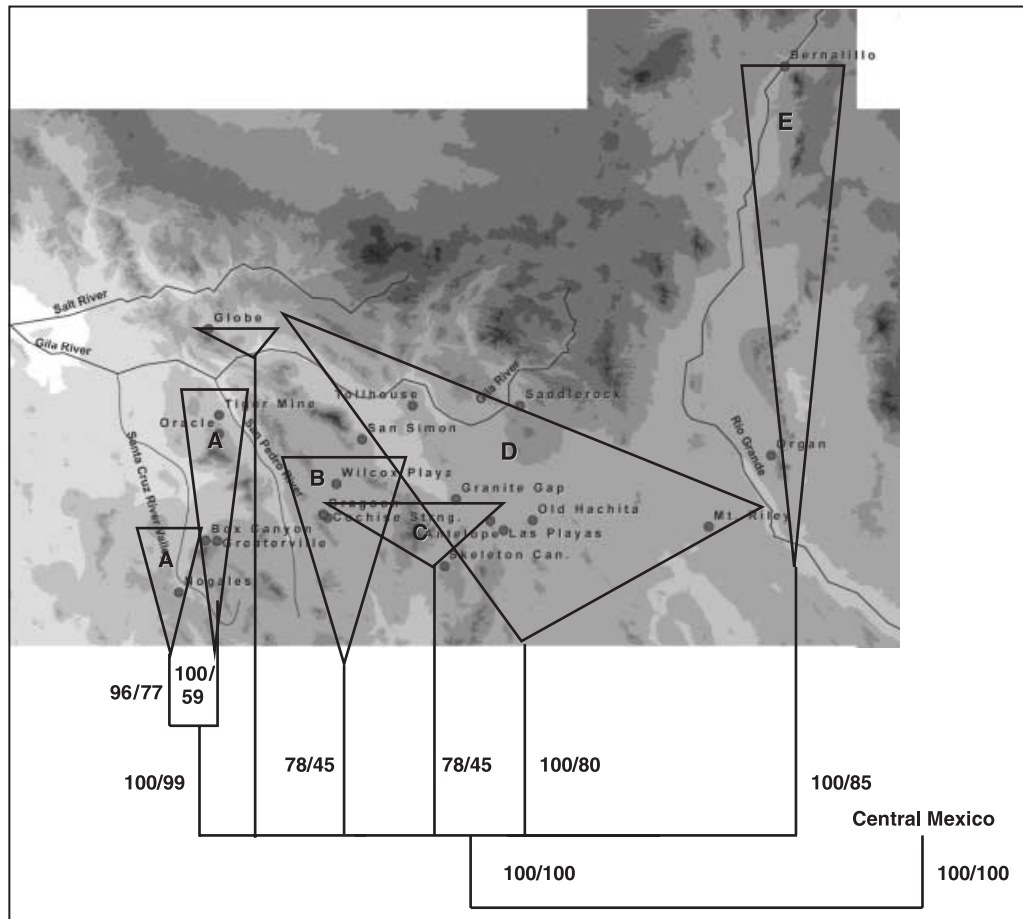

Fig. 6 Simplified consensus tree showing relationship between major clades, and their approximate geographic distribution in the study area. Numbers on nodes indicate Bayesian posterior probability/bootstrapping support. The letters on clades correspond to geographic distribution as follows: A, Santa Cruz River valley; B, Sulfur Springs River valley; C, Wilcox, Skeleton Canyon; D, Continental Divide; E, East of the Rio Grande.

Additionally, there was poor resolution of the relationships between these major clades. Alternative optimality criteria recovered different relationships among these lineages, and these relationships were poorly supported in the Bootstrap and Bayesian analyses. Likewise, preliminary exploration of the data set suggested that these relationships were very sensitive to taxon sampling. The weak support for the higher-level relationships between regions is likely due to the very short internodes between these lineages. The major mitochondrial lineages in this species appear to have diverged nearly simultaneously, suggesting that the different biogeographic regions may have been isolated by a single historical event.

The overall phylogeographic patterns seem to be in agreement with at least some of the previous research on the biogeography of the Madrean sky islands. Sullivan (1994) identified the Rio Grande river valley as a major barrier to dispersal for montane populations of the Mexican woodrat *Neotoma mexicana* and also found that populations

from the Sulfur Springs Valley, west of the Gila, were basal with respect to all other populations. Sullivan’s study also identified topography as a good predictor of phylogeographic relationships. Similarly, Maddison & McMahon (2000) found that populations of the jumping spider *Habronatus pugilis* separated by the San Pedro and Santa Cruz river valleys were isolated from one another, and Barber (1999b), found strong support for the monophyly of populations of canyon tree frogs (*Hyla arenicolor*) from the Santa Catalina and Santa Rita mountains. Finally, recent work (Smith & Farrell 2005) indicates that the Chihuahuan desert species *Moneilema armatum* LeConte shares a similar biogeographic pattern, with populations on either side of the Rio Grande genetically isolated from one another. Although this species occurs primarily in low-elevation, desert habitats, and is sympatric with *M. appressum* only in a narrow elevational band around 1300 m, the river appears to represent a significant barrier to dispersal for both species.

The coalescent estimates of migration rates also offer support for a history of isolation. The San Pedro River and the Rio Grande appear to present significant barriers to dispersal; populations on either side of these barriers show low levels of gene exchange but there was evidence for appreciable gene flow between the adjacent Sulfur Springs Valley and the Continental Divide regions, which are not separated by major biogeographic barriers. Although in some contrasts there was only marginally significant support for divergence over ongoing migration, it is unlikely that this reflects a true history of isolation by distance, as the relatively high P values in these cases were influenced by the a priori maxima selected. Indeed, although decreasing values for M_{\max} did not result in significant changes in the posterior probabilities over all, lower values did result in large decreases in the P values for contrasts that were marginally significant at $M = 6$.

The analysis of migration between populations using Mantel tests indicated that topographic barriers to dispersal were a significant determinant of migration rates, even when accounting for the effect of distance. Some authors have questioned the validity of the partial Mantel method to partition sources of variance. Raufaste & Rousset (2001), for example, argued that partial Mantel tests may underestimate type I error rates, leading to the erroneous rejection of null hypotheses. However, Legendre (2000) showed using simulations that for the most common implementations of the partial Mantel test (including those used here), type I errors are correctly estimated for sample sizes greater than 10. It is therefore likely that the results in this case are genuinely significant because the sample size (18 populations and 306 comparisons) is much larger than those for which type I error rates were underestimated in Legendre's simulations, and because the inferred P values are well within the margin of significance.

However, the nested clade analysis suggests a history of isolation by distance, rather than allopatric fragmentation. The conflict between this result and those of the coalescent analyses may have arisen because many divergent haplotypes could not be included in the analysis. This explanation seems particularly likely given that the excluded haplotypes included all but one from the region east of the Rio Grande, which was significantly isolated from all other populations in the coalescent analysis. Indeed, nested clade analyses of networks that incorporated all haplotypes (not shown) by either manually increasing the reconnection limit or by using the constrained parsimony approach described in Templeton & Sing (1993) suggest that when all samples are included the pattern is more consistent with allopatric fragmentation. However, as discussed above, including all haplotypes required connections that exceeded the 95% confidence interval, and so these results might also be

unreliable. Indeed, it may be that COI is simply evolving too quickly in this species to be appropriately analysed using nested clade analysis; ultimately it may be necessary to gather additional data from more slowly evolving genes to unambiguously resolve the biogeographic history of this species.

Knowles & Maddison (2003) have criticized nested clade analysis because it does not provide an explicit statistical method to distinguish between different historical models. Although the results in this case were in conflict with the coalescent analyses, Templeton's method still served as a useful heuristic tool for describing biogeographic patterns and further exploration of its utility seems warranted.

Finally, although all of the coalescent estimates of migration rates suggest a history of isolation, the divergence time estimates produced by MDIV suggest that these patterns are quite old. Whereas the packrat midden data that motivated this study documents changes that occurred over the last 40 000 years, the estimated divergence times between populations are at least an order of magnitude older. The estimated divergence times between regions are older still, between 1 and 1.5 Myr. Of course, estimates of divergence times drawn from a single locus must be treated with some skepticism, given that the stochastic nature of the coalescent process may result in considerable variance in the time to common ancestry. However, the divergence times estimated in this case were quite consistent in all contrasts between regions. These findings, then, would seem to strongly rule out recent global climate change (i.e. changes that occurred within the last 40 000 years) as the causal mechanism underlying the apparent history of habitat fragmentation in this species.

However, global climate models developed by Paillard (1998) indicate that major interglacial warming events have occurred approximately every hundred thousand years, with extreme increases in temperature occurring approximately 1.3 and 0.95 million years ago (Ma). It is therefore likely that the dramatic range changes that many plants and animals experienced at the end of the last glacial occurred repeatedly throughout the Pleistocene. Additionally, the estimated divergence times found in this species are quite similar to those inferred for other species of *Moneilema*. For example, populations of *M. armatum* in the continental divide region appear to have diverged from those in central Mexico approximately 1.5 Ma, and populations of *M. gigas* in southeastern Arizona diverged from populations in coastal Sonora between 1 and 1.5 Ma (Smith & Farrell 2005). It is therefore not unreasonable to propose that the range fragmentation found in *M. appressum* may have been driven by climate fluctuations in the lower Pleistocene, and that these fluctuations may have produced significant range shifts in a number of other species in this region.

Conclusions

The consensus of these analyses suggest high degrees of geographic structuring in the genetic relationships within this flightless beetle, and indicate that topography is an important determinant of migration rates between populations. The San Pedro River and the Rio Grande in particular appear to represent significant barriers to dispersal for these and many other organisms in this region. However, it remains ambiguous whether this structure has resulted from allopatric fragmentation or ongoing restricted gene flow.

Although the divergence times estimated here strongly reject Holocene climate change as the mechanism underlying any putative isolation, comparisons of the divergence times estimated here with established models of climate change and with data from other species in this genus suggest that earlier interglacial events could have been responsible. Although the imprint of Pleistocene climate change on genetic relationships may be insignificant in some habitats, the apparent signature of climate history in these cactus beetles suggests that many desert organisms may have had similar responses. Additionally, the reflection of Pleistocene history in *Moneilema appressum* and other species in this genus, suggests the possibility that the older history of the American deserts may similarly be reflected in the phylogeny of the genus *Moneilema*, which includes an array of other cactus-associated species.

Acknowledgements

We wish to thank the Coronado and Gila National Forests for permission to collect in National Forest lands, as well as the Mexican Secretary of the Environment and Natural Resources (SeMARNat) and the Mexican Secretary of External Relations for permission to conduct research in the Republic of Mexico (Permit nos DAN-03200, DOO-022916). We are indebted to the many people who helped in the completion of the field and laboratory research for this project, particularly Molly Moore, Nelia Padilla, Dylan and Migue Wilmsen, and Derrick Zwickl. We also wish to thank Drs Olle Pellmyr, Naomi Pierce, and John Wakeley, and the members of the Farrell laboratory for helpful comments on this manuscript, and Drs T. R. Van Devender and T. Burgess for useful discussion. This project was funded in part by the OEB Student Research Grant, Putnam Expedition Grant to the MCZ, and by an NSF Doctoral Dissertation Improvement Grant to C. Smith (Award Number DEB-0073291); we gratefully acknowledge this financial support.

References

- Arbogast BS, Edwards SV, Wakeley J, Beerli P, Slowinski JB (2002) Estimating divergence times from molecular data on phylogenetic and population genetic timescales. *Annual Review of Ecology and Systematics*, **33**, 707–740.
- Ayoub N, Riechert SE (2004) Molecular evidence for Pleistocene glacial cycles driving diversification of a North American desert spider, *Agelenopsis aperta*. *Molecular Ecology*, **13**, 3453–3465.
- Barber PH (1999a) Patterns of gene flow and population genetic structure in the canyon treefrog, *Hyla arenicolor* (Cope). *Molecular Ecology*, **8**, 563–576.
- Barber PH (1999b) Phylogeography of the canyon treefrog, *Hyla arenicolor* (Cope) based on mitochondrial DNA sequence data. *Molecular Ecology*, **8**, 547–562.
- Boyd A (2002) Morphological analysis of sky island populations of *Macromeria viridiflora* (Boraginaceae). *Systematic Botany*, **27**, 116–126.
- Brower AVZ (1996) Parallel race formation and the evolution of mimicry in *Heliconius* butterflies: a phylogenetic hypothesis from mitochondrial DNA sequences. *Evolution*, **50**, 195–221.
- Brown D (1994) *Biotic Communities: Southwestern United States and Northwestern Mexico*. University of Utah Press, Salt Lake City, Utah.
- Brown JH, Lomolino MV (1998) *Biogeography*. Sinauer Associates, Sunderland, Massachusetts.
- Byers JA (1999) Great circle distance calculated between points on earth given latitude and longitude. Western Cotton Research Laboratory, Phoenix, Arizona.
- Clement M, Posada D, Crandall K (2000) tcs: a computer program to estimate gene genealogies. *Molecular Ecology*, **9**, 1657–1660.
- Darwin C (1859) *The Origin of Species by Means of Natural Selection*. John Murray, London.
- Elias SA (1987) Paleoenvironmental significance of late Quaternary insect fossils from packrat middens in south-central New Mexico. *Southwestern Naturalist*, **32**, 383–390.
- Elias SA, Van Devender TR, De Baca R (1995) Insect fossil evidence of late Glacial and Holocene environments in the Bolson de Mapimi, Chihuahuan desert, Mexico: Comparisons with the paleobotanical record. *Palaeos*, **10**, 454–464.
- Elias SA, Van Devender TR (1992) Insect fossil evidence of late Quaternary environments in the northern Chihuahuan desert of Texas and New Mexico: comparisons with the paleobotanical record. *Southwestern Naturalist*, **37**, 101–116.
- Farrell BD (2001) Evolutionary assembly of the milkweed fauna: cytochrome oxidase I and the age of *Tetraopes* beetles. *Molecular Phylogenetics and Evolution*, **18**, 467–478.
- Goudet J (2002) *FSTAT*. Institute of Ecology, UNIL, Lausanne, Switzerland.
- Heald WF (1951) Sky islands in Arizona. *Natural History*, **60**, 56–63.
- Hewitt GM (1996) Some genetic consequences of ice ages, and their role in divergence and speciation. *Biological Journal of the Linnean Society*, **58**, 247–271.
- Hewitt G (2000) The genetic legacy of the Quaternary ice ages. *Nature*, **405**, 907–913.
- Huelsenbeck JP, Ronquist F (2001) MRBAYES: Bayesian inference of phylogeny. *Bioinformatics*, **17**, 754–755.
- Klicka JZ, Zink RM (1997) The importance of recent ice ages in speciation: a failed paradigm. *Science*, **277**, 1666–1669.
- Klicka JZ, Zink RM (1999) Pleistocene effects on North American songbird evolution. *Proceedings of the Royal Society of London. Series B, Biological Sciences*, **266**, 695–700.
- Knowles LL (2000) Tests of Pleistocene speciation in montane grasshoppers (Genus *Melanoplus*) from the sky islands of western North America. *Evolution*, **54**, 1337–1348.
- Knowles LL (2001) Did the Pleistocene glaciations promote divergence? Tests of explicit refugial models in montane grasshoppers. *Molecular Ecology*, **10**, 691–701.
- Knowles L, Maddison W (2003) Statistical phylogeography. *Molecular Ecology*, **11**, 2623–2635.

- Knowles LL, Otte D (2000) Phylogenetic analysis of montane grasshoppers from western North America (Genus *Melanoplus*, Acrididae: Melanoplinae). *Annals of the Entomological Society of America*, **93**, 421–431.
- Legendre P (2000) Comparisons of permutation methods for the partial correlation and partial Mantel tests. *Journal of Statistics and Computer Simulation*, **67**, 37–73.
- Lingafelter S (2003) New host and elevational records for *Moneilema appressum* (Coleoptera: Cerambycidae). *Journal of the New York Entomological Society*, **111**, 51–56.
- Linhart YB, Permolli AC (1994) Genetic variation in central and disjunct populations of *Lilium parryi*. *Canadian Journal of Botany*, **72**, 79–85.
- Linsley EG, Chemsak JA (1984) *The Cerambycidae of North America, Part VII, No. 1: Taxonomy and Classification of the Subfamily Lamiinae, Tribes Parmenini Through Acanthoderini*. University of California Press, Berkeley.
- Maddison DR, Maddison WP (2001) MacClade 4.04: Analysis of phylogeny and character evolution. Sinauer Associates, Sunderland, Massachusetts.
- Maddison WP, McMahon M (2000) Divergence and reticulation among montane populations of a jumping spider (*Habronattus pugillis* Griswold). *Systematic Biology*, **49**, 400–421.
- Mantel NA (1967) The detection of disease clustering and a generalized regression approach. *Cancer Research*, **27**, 209–267.
- Masta SE (2000) Phylogeography of the jumping spider *Habronattus pugillis* (Araneae: Salticidae): recent vicariance of sky island populations? *Evolution*, **54**, 1699–1711.
- Mayr E (1942) *Systematics and the Origin of Species*. Harvard University Press, Cambridge, Massachusetts.
- Mayr E (1963) *Animal Species and Evolution*. Harvard University Press, Cambridge, Massachusetts.
- McCarten NF (1981) Fossil cacti and other succulents from the late Pleistocene. *Cactus and Succulent Journal*, **53**, 122–123.
- McCord RD (1994) Phylogeny and biogeography of the land snail, *Sonorella*, in the Madrean Archipelago. In: *Biodiversity and Management of the Madrean Archipelago: The Sky Islands of Southwestern United States and Northwestern Mexico* (eds DeBano LF, Ffolliott PF, Ortega-Rubio A *et al.*), pp. 317–323. US Department of Agriculture, Fort Collins, Colorado.
- Nielsen R, Slatkin M (2000) Analysis of populations subdivision using di-allelic models. *Evolution*, **52**, 44–50.
- Nielsen R, Wakeley J (2001) Distinguishing migration from isolation: a Markov chain Monte Carlo approach. *Genetics*, **158**, 885–896.
- Paillard D (1998) The timing of Pleistocene glaciations from a simple multiple-state climate model. *Nature*, **391**, 378–381.
- Palumbi SR (1996) The polymerase chain reaction. In: *Molecular Systematics*, 2nd edn (eds Hillis D, Moritz C, Mable BK), pp. 205–247. Sinauer, Sunderland.
- Posada D, Crandall KA (1998) MODELTEST: testing the model of DNA substitution. *Bioinformatics*, **14**, 817–818.
- Posada D, Crandall KA, Templeton AR (2000) GEODIS: a program for the cladistic nested analysis of the geographical distribution of genetic haplotypes. *Molecular Ecology*, **9**, 487–488.
- Raske AG (1966) *Taxonomy and Bionomics of the Genus Moneilema (Coleoptera: Cerambycidae)*. University of California, Berkeley.
- Raufaste N, Rousset F (2001) Are partial Mantel tests adequate? *Evolution*, **55**, 1703–1705.
- Saraste M (1990) Structural features of cytochrome oxidase. *Quarterly Reviews in Biophysics*, **23**, 331–366.
- Slentz S, Boyd AE, McDade LA (1999) Morphological differentiation among Madrean sky island populations of *Castilleja austromontana* (Scrophulariaceae). *Madroño*, **46**, 100–111.
- Smith CI, Farrell BD (2005) Recent range expansions in the flightless longhorn cactus beetles *Moneilema gigas* and *M. armatum* in response to Pleistocene climate changes. *Molecular Ecology*, **14**, 1025–1044.
- Smouse PE, Long JC, Sokal RR (1986) Multiple regression and correlation extensions of the Mantel test of matrix correspondence. *Systematic Zoology*, **35**, 627–632.
- Stephan SJ, Zawadzki C, Heaney LR (2003) Molecular phylogeny of the endemic Philippine rodent *Apomys* (Muridae) and the dynamics of diversification in an oceanic archipelago. *Biological Journal of the Linnean Society*, **80**, 699–715.
- Sullivan RM (1994) Micro-evolutionary differentiation and biogeographic structure among coniferous forest populations of the Mexican woodrat (*Neotoma mexicana*) in the American Southwest: a test of the vicariance hypothesis. *Journal of Biogeography*, **21**, 369–389.
- Sunnucks P, Hales DF (1996) Numerous transposed sequences of mitochondrial cytochrome oxidase 1–11 in aphids of the genus *Sitobion* (Hemiptera: Aphididae). *Molecular Biology and Evolution*, **13**, 510–524.
- Swofford D (2002) *PAUP**. Sinauer Associates, Sunderland, Massachusetts.
- Templeton AR (1998) Nested Clade Analyses of phylogeographic data: testing hypotheses about gene flow and population history. *Molecular Ecology*, **7**, 381–397.
- Templeton AR (2004) Statistical phylogeography: methods of evaluating and minimizing errors. *Molecular Ecology*, **13**, 789–809.
- Templeton AR, Boerwinkle E, Sing CF (1987) A cladistic analysis of phenotypic association with haplotypes inferred from restriction endonuclease mapping I: basic theory and an analysis of alcohol dehydrogenase activity in *Drosophila*. *Genetics*, **117**, 343–351.
- Templeton AR, Sing CF (1993) A cladistic analysis of phenotypic association with haplotypes inferred from restriction endonuclease mapping IV: nested analyses with cladogram uncertainty and recombination. *Genetics*, **134**, 659–669.
- Thompson RS, Anderson KH (2000) Biomes of western North American at 18 000, 6000, and 0, ¹⁴C yr BP reconstructed from pollen and packrat midden data. *Journal of Biogeography*, **27**, 555–584.
- Van Devender TR (1990a) Late quaternary vegetation and climate of the Chihuahuan desert, United States and Mexico. In: *Packrat Middens: The Last 40 000 Years of Biotic Change* (eds Betancourt J, Van Devender TR, Martin PS), pp. 104–133. University of Arizona Press, Tucson.
- Van Devender TR (1990b) Late quaternary vegetation and climate of the Sonoran desert, United States and Mexico. In: *Packrat Middens: The Last 40 000 Years of Biotic Change* (eds Betancourt J, Van Devender TR, Martin PS), pp. 134–162. University of Arizona Press, Tucson.
- Wakeley J (1996) Distinguishing migration from isolation using the variance of pairwise differences. *Theoretical Population Biology*, **49**, 39–57.
- Wakeley J (2000) The effects of subdivision on the genetic divergence of populations and species. *Evolution*, **54**, 1092–1101.
- Wallace AR (1862) Narrative of a search after birds of paradise. *Proceedings of the Zoological Society of London*, **XX**, 153–161.
- Warshall P (1994) The Madrean Sky Island Archipelago: a planetary overview. In: *Biodiversity and Management of the Madrean*

Archipelago: The Sky Islands of Southwestern United States and Northwestern Mexico (eds De Bano LF, Ffolliott PF, Ortega-Rubio A *et al.*), pp. 6–18. US Department of Agriculture, Fort Collins, Colorado.

Wilf P, Cúneo NR, Kirk R, Johnson *et al.* (2003) High plant diversity in Eocene South America: evidence from Patagonia. *Science*, **300**, 122–125.

Wright S (1978) *Evolution and the Genetics of Populations, Vol. 4: Variability Within and Among Natural Populations*. University of Chicago Press, Chicago.

Chris Smith studies the role of geographic and ecological factors in determining gene flow, population structure, and species formation, and is particularly interested in the evolution of desert ecosystems. His current research examines the role of geographic structure in the diversification of yuccas and yucca moths. Brian Farrell is broadly interested in the interaction between insects and plants and the role of ecology in long-term evolutionary change, including adaptive radiations.
